



# Strain Gauge Measuring Amplifier BA 662

## Manual



### Table of Contents

<b>1. Safety precautions</b> .....	<b>2</b>
<b>2. Function</b> .....	<b>2</b>
<b>3. Spezifikation</b> .....	<b>3</b>
3.1. General technical data .....	3
3.2. Circuit diagram .....	4
3.3. Dimensions .....	4
3.4. Anschlüsse .....	5
3.5. How to connect signal output .....	5
3.6. Trigger input .....	5
<b>4. Operation</b> .....	<b>6</b>
4.1. How to operate the keys .....	6
4.2. Amplification .....	6
4.3. Zero alignment .....	6
4.4. Filter .....	6
4.5. Signal output .....	6
4.6. LED-Status .....	7
4.7. Restart .....	7
4.8. Factory setting (Reset) .....	7
<b>5. Using the Software ASTAS (USB)</b> .....	<b>7</b>
<b>6. EG-Konformitätserklärung</b> .....	<b>8</b>

The software **ASTAS** and further information on the BA 662 can be found on our website [www.ast.de](http://www.ast.de).

A.S.T. - Angewandte System Technik GmbH, Mess- und Regeltechnik  
 Marschnerstraße 26 01307 Dresden  
 Telefon (03 51) 44 55 30 Telefax (03 51) 44 55 555  
[www.ast.de](http://www.ast.de) vertrieb.dd@ast.de

### 1. Safety precautions

In this operating manual, the installation, putting into operation and the operation itself of the Strain Gauge Bridge Amplifier BA 662 is described. It is assumed that all measures are taken by qualified staff only who have adequate knowledge in the fields of measuring and control engineering.



**ATTENTION!** Any non-compliance with these safety precautions may result in severe damage to property and health.

The Strain Gauge Bridge Amplifier BA 662 has been designed to the purpose of amplifying the output signals of sensors with metal-foil strain gauges, preferably force transducers and transform them into standard signals. Any other application is regarded contrary to the intended purpose. The manufacturer does not accept any liability for damages resulting from such inappropriate usage. In this case it is the user alone who has to bear the risk.

Type BA 662 must not be used as the sole means to prevent dangerous conditions of machines and plants. All machines and plants must be constructed in such a way (e.g. by using mechanical stops, limit switches) that a condition of failure does not result in a situation of severe danger.

It must be made sure that any erroneous setting or malfunction of the unit or its breakdown cannot cause damage or be a risk to the operating staff or other persons.

The unit must be installed and connected in compliance with the current DIN- and VDE-standards. Supply cables and signal lines shall be installed so that interference signals such as electrical interference do not have any adverse effects on the function of the equipment.

The device does not contain any components that require maintenance. Repairs shall be carried out by the manufacturer only.

### 2. Function

The Strain Gauge Bridge Amplifier BA 662 is a digital amplifier for the low-drift amplification of the output signals of sensors with metal-foil strain gauges, preferably force transducers to supply a standard signal of (-10/0...10) VDC or (0/4...20) mA.

An internal voltage source provides the stabilized feeding voltage for the sensor. The power is supplied by an unstabilized source of (9...36) VDC. The Strain Gauge Bridge Amplifier is delivered in a case for standard rails in accordance with DIN EN 50022-35.

The BA 662 is delivered with a factory setting for an input signal of 2mV/V and a corresponding output signal of  $\pm 10V$  or 20mA. The other input signal ranges 0.1mV/V to 7mV/V can be generated internally from the 2mV/V factory adjustments. The different settings of the factory adjustments (zero point and gain) can be changed by the user through keys.

By an optically separated input, the zero-setting can be carried out by means of a superior control and through the trigger input. The overload limit is not affected by such a zeroing, which means that 100 % of the end-value adjustment of the sensor remains as end value. An existing preload by a container can thus be set zero.

### 3. Spezifikation

#### 3.1. General technical data

<b>Class of accuracy at input signal 2mV/V</b>	<b>% FSR</b>	<b>&lt; 0.02 (typ.)</b>	
Connection for strain gauge sensor		4- or 6-wire	
Bridge resistance / range of input impedance	Ω	58...2000 (up to 6 loadcells each 350 Ω)	
Input signal range (+Si/-Si)	mV/V	0.1/ 0.25/ 0.5/ 1.0/ 1.5/ 2.0/ 3.0/ 4.0/ 5.0/ 7.0	
Excitation voltage (+Ex/-Ex)	VDC	±2.5	
<b>Norm Output</b>			
Current Output	mA	0/ 4... +20; 0...24	
Voltage Output	V	-10/-5...0...+5/ +10	
Load resistance (burden)	Ω	≤ 350	≥ 1000
<b>Measurement Characteristics</b>			
Conversion rate	Sps	6 ... 3200	
Resolution of the A/D Converter	Bit	24	
Filter	Hz	0.8...2000	
<b>Error at S=2mV/V</b>			
Nonlinearity	%FSR	0.0025	
Noise (at measurement rate)	%FSR	0.002 (0.8Hz) ... 0.009 (2000Hz)	
Input sensitivity for 1 LSB	nV	150	
Zero drift	%/ 10K	<0.01	
<b>Power Supply</b>			
Input range	VDC	9 ... 36	
Power consumption (without sensor)	W	3	
<b>Environmental Conditions</b>			
Operating temperature range	°C	- 20...+ 60	
Storage temperature range	°C	- 25...+ 85	
<b>Construction</b>			
Plastic housing for DIN-rail mounting			
Weight	kg	0.2	
Dimensions (W x H x D)	mm	22.5 x 114.5 x 99	
Environmental protection (EN 50529)		IP 20	
Terminal block, wire size	mm <sup>2</sup>	0.14 ... 2.5	

\*Software  - Download over [www.ast.de](http://www.ast.de)

### 3.2. Circuit diagram

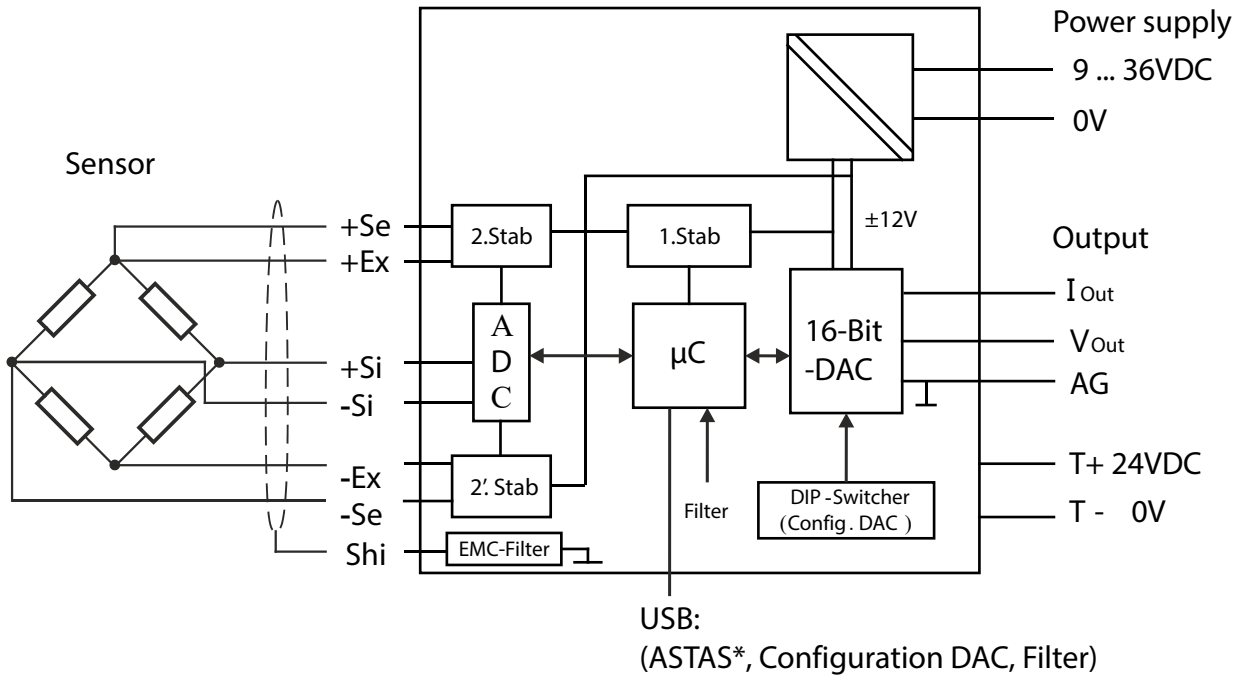

### 3.3. Dimensions

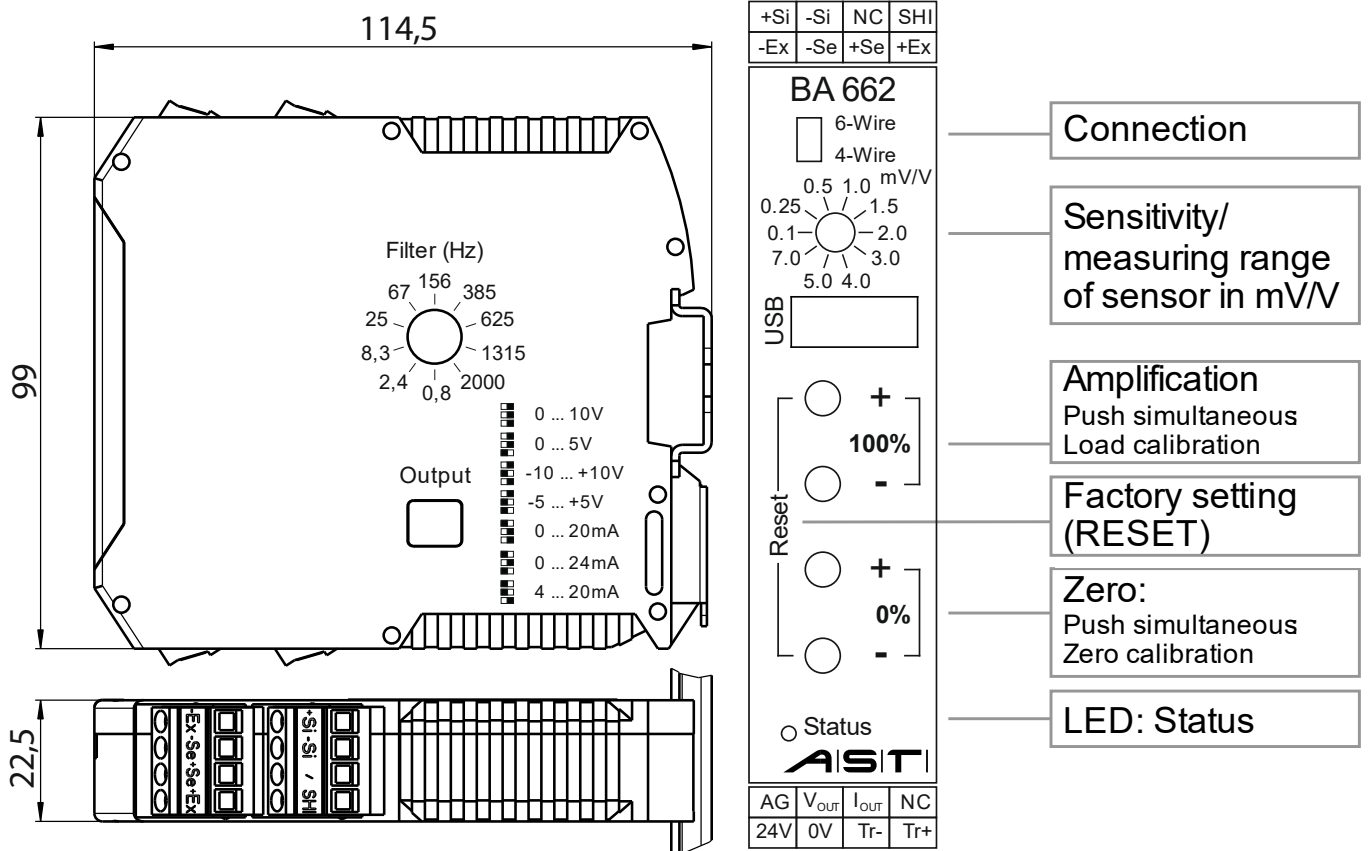

### 3.4. Anschlüsse

Terminal connection	Description	
-Ex	neg. Excitation voltage	Sensor with 6-wire
-Se	neg. Sense signal	
+Se	pos. Sense signal	
+Ex	pos. Excitation voltage	
+Si	pos. Signal	
-Si	neg. Signal	
NC	not connected	
SHI	Shield	
AG	Ground for output signal	Output signal
V <sub>out</sub>	Voltage output	
I <sub>out</sub>	Current output	
NC	not connected	
24V	Supply voltage	Power supply
0V	Supply voltage ground	
Tr+	Trigger 24V	electrically isolated input
Tr-	Trigger 0V	

#### Installation recommendations

- Use shielded cables.
- Use the largest possible cable cross section (Error due to cable extension).
- Lay the measuring lines separately from the power supply lines.
- At the force transducers and the measuring amplifier, make as short as possible a connection to earth, in particular in strong electromagnetic fields.
- Additionally, lay an equipotential bonding parallel to the measuring line.
- Keep away from stray fields of motors, transformers and contactors.
- Connect force transducers, amplifier, mains unit, and indicator / processor unit with earth in one place only.
- Set the slide switch for the sensing line (6- or 4-wire) according to the sensor connection.

### 3.5. How to connect signal output

The Bridge Amplifier BA 662 provides different output signals, depending upon the setting of the slide switches. (see 4.5).



**NOTE!** Either the current output or the voltage output can be used, not both at the same time.



**TIP:** to form the sum, current outputs of several BA662 can be connected in parallel. In this case, 12V should not be exceeded at the standard output and the maximum load (load resistance) be  $< 12V / \Sigma I_{out}$ . Voltage outputs must not be connected in parallel.

### 3.6. Trigger input

The BA662 has an optically separate trigger input so that the zero-setting can be carried out by means of a superior control. The overload limit is not affected by such a zeroing.

The function is started by a 24 VDC trigger impulse



**Note!** The measuring amplifier is protected against reverse polarity.

## 4. Operation

### 4.1. How to operate the keys

Keys individually / short: Setting of the signal output

Keys individually / long (2s): Fast setting of the signal output

### 4.2. Amplification

Switch position	0	1	2	3	4	5	6	7	8	9
Measuring range (mV/V)	0.1	0.25	0.5	1.0	1.5	2.0	3.0	4.0	5.0	7.0

- Keys >100% +< or >100% -<: Fine adjustment of the output signal/ end value
- Keys >100% +< and >100% -< simultaneously (2s): Sets the current input value to 100% of the output signal (final value adjustment).



**NOTE!** In case of changing the amplifier output by means of keys > 100 % +< or > 100% -< there should always be a zero-alignment check..

### 4.3. Zero alingment

- Keys >0% +< or. >0% -<: Fine adjustment of the output signal/ zero point
- Keys >0% + < and >0% - < simultaneously (2s): Sets the applied input signal at the output to the zero point (zero adjustment/ zero adjustment)



**NOTE!** Zero-values are saved permanently 7 seconds after last push button action. During saving LED blinks red for a short time.

### 4.4. Filter

Through a low-pass filter, the output signal can be set in 10 stages, from 0.8 to 2000Hz.

Filter (Hz)	0.8	2.4	8.3	25	67	156	385	625	1315	2000
Internal sample rate (Hz)	6	12	25	50	100	200	400	800	1600	3200

### 4.5. Signal output

DIP switch explanation:

Settings (DIP 1...3):

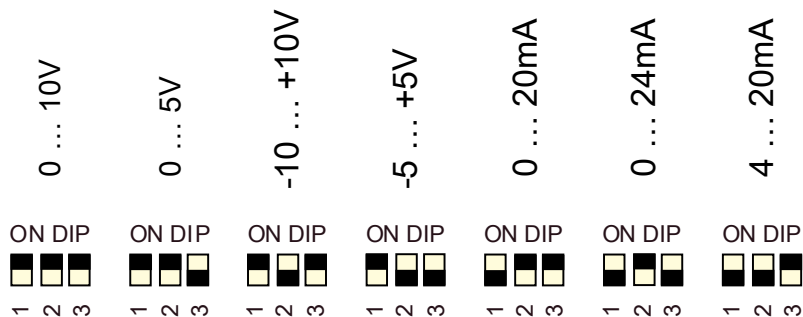
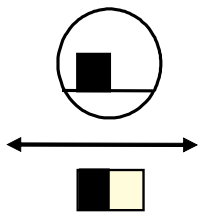

**ATTENTION!** In case of exceedance of the input signal of >-120%, the analogue output is set to the maximum positive initial value.

In case the input signal lies in the range between -120% and 0%, the minimum analogue signal is released at the unipolar voltage output and the current output respectively (see graphs).!

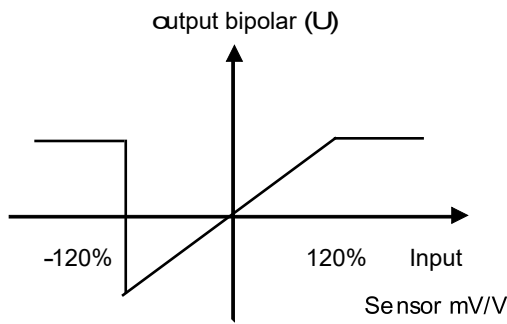

Graph 1  
Output signal in case of error (bipolar)  
Output signal -5...5V, -10...10V

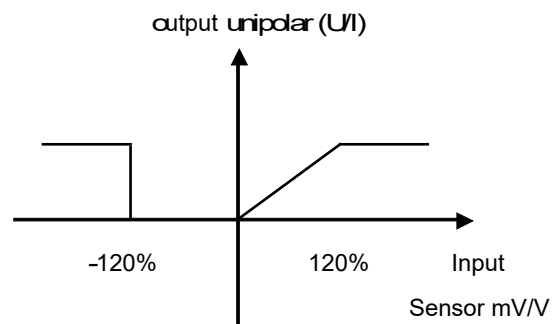

Graph 2  
Output signal in case of error (unipolar)  
Output signal 0...5/10V, 0/4...20/24mA

#### 4.6. LED-Status

LED display	Explanation	Error description
Green	Ready for operation	<ul style="list-style-type: none"> <li>No error</li> </ul>
Red 1 x flashing	ADC-Overload	<ul style="list-style-type: none"> <li>Error at connections of sensor lines</li> <li>Cable break in sensor line</li> <li>Switch for 6- and 4-wire not accordingly connected</li> </ul>
Red 2x flashing	Indicates overload or underload	<ul style="list-style-type: none"> <li>Exceed of maximum load of 120% of nominal sensitivity, or exceed minimum load (see too 4.5)</li> </ul>
Red 3x flashing	TEDS error	<ul style="list-style-type: none"> <li>Error in the memory of the automatic sensor recognition</li> <li>(only option with TEDS)</li> </ul>
Red 4 x flashing	Output > 100%	<ul style="list-style-type: none"> <li>The amplification at the output is set too high.</li> </ul>
Red 5 x flashing	Current output open or overheating DAC	<ul style="list-style-type: none"> <li>Output side not closed</li> <li>Cable break at output</li> <li>Thermal overheating - cooling necessary</li> </ul>
Red 6 x flashing	Hardware error	<ul style="list-style-type: none"> <li>General error – restart necessary</li> </ul>

#### 4.7. Restart

Keys >100% -< and >0% +< simultaneously: A restart is carried out. All settings are saved.

#### 4.8. Factory setting (Reset)

Keys >100% +< and >0% - < simultaneously 2s: All zero point and end value adjustments of the ten measuring ranges are deleted and reset to the factory settings.



**NOTE!** After reset to factory settings, the amplifier has to be newly adjusted to the sensor!

### 5. Using the Software ASTAS (USB)

Load the software **ASTAS** from our website [www.ast.de](http://www.ast.de).



**TIP: Linearization:** If the measured values between zero and rated load should deviate from the real load, up to four additional points can be set to increase the measurement accuracy. These measuring points can be made in any order, similar to the input of the zero point and end point. After entering all of the calibration points, the result must be stored.

## 6. EG-Konformitätserklärung

**A.S.T. - Angewandte System Technik GmbH**  
Mess- und Regeltechnik



### EU-Konformitätserklärung EC Declaration of Conformity

No. 06/17

Hersteller: A.S.T. - Angewandte System Technik GmbH  
Manufacturer: Mess- und Regeltechnik

Anschrift: Marschnerstraße 26, 01307 Dresden  
Address: Bundesrepublik Deutschland

Produkt-  
bezeichnung: DMS - Messverstärker BA 662  
Product description: Strain gauge measuring amplifier BA 662

Das bezeichnete Produkt stimmt in der von uns in Verkehr gebrachten Ausführung mit den Vorschriften folgender Europäischer Richtlinien überein:  
The product described above in the form as delivered is in conformity with the provisions of the following European Directives:

2014/30/EU Richtlinie des Rates zur Angleichung der Rechtsvorschriften der Mitgliedsstaaten über die elektromagnetische Verträglichkeit.  
Council Directive on the approximation of the laws of the Member States relating to electromagnetic compatibility.

Die Konformität mit der Richtlinie 2014/30/EU wird nachgewiesen durch die Einhaltung folgender harmonisierter Normen:  
Conformity to the Directive 2014/30/EU is assured through the application of the following harmonised standards:

Störfestigkeit: Interference resistance:	DIN EN 61000-6-2:2006-03
Störaussendung: Emitted interference:	DIN EN 61000-6-3:2011-09

Dresden, den 27.02.2017

  
gez. Dr.-Ing. Gerd Heinrich  
Qualitätssicherung / Quality assurance

A.S.T. - Angewandte System Technik GmbH  
Mess- und Regeltechnik  
Marschnerstraße 26, D-01307 Dresden

<http://www.ast.de>  
Tel (0351) 44 55 30  
Fax (0351) 4455-451

Geschäftsführer:  
Matthias Boeck  
HRB-Nr.: 5910  
Kreisgericht  
Dresden

Bankverbindung:  
Ostsächsische  
Sparkasse Dresden  
BLZ 850 503 00  
Konto 3120 1040 93